

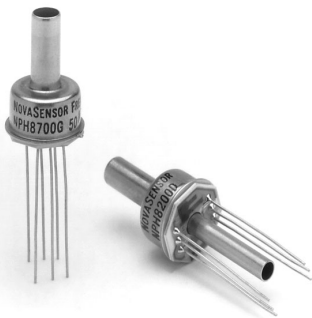

GE NovaSensor

NPH Series

**Solid State
Pressure Sensor
(Low Pressure)**



Description

An integrated circuit silicon sensor chip is housed in a standard TO-8 electrical package that is printed circuit board mountable.

The latest techniques in VLSI and micromachining have been used to ion implant piezoresistive strain gages into a Wheatstone bridge configuration that is integrally formed on a micromachined silicon diaphragm. As with all NovaSensor® silicon sensors, the NPH Series employs SenStable® processing technology, providing excellent output stability. Constant current excitation to the sensor produces a voltage output that is linearly proportional to the input pressure.

The user can provide standard signal conditioning circuitry to amplify the 100mV output signal. The sensor is compatible with most noncorrosive gases and dry air.

A laser-trimmed, thick-film resistor network on a hybrid ceramic substrate provides temperature compensation.

Features

- Solid State, High Reliability
- Standard TO-8 Package Suitable for PC Board Mount
- Low Cost, Small Size
- Available in Gage, Absolute, and Differential Pressure Versions
- Media Compatible with Noncorrosive Gases and Dry air
- Output Signal of 100mV @ 1.5mA
- Thermal Accuracy FSO 0.5% Typical
- Overpressure Capability to 5 Times Maximum Rated Pressure
- Three Standard Ranges: 0–10" H₂O, 0–1 psi, and 0–5psi
- Nonlinearity 0.05% FSO Typical
- Standard 3/16" OD Pressure Port
- Ceramic Substrate with Temperature Compensation Resistors

Schematic Diagram (with hybrid)

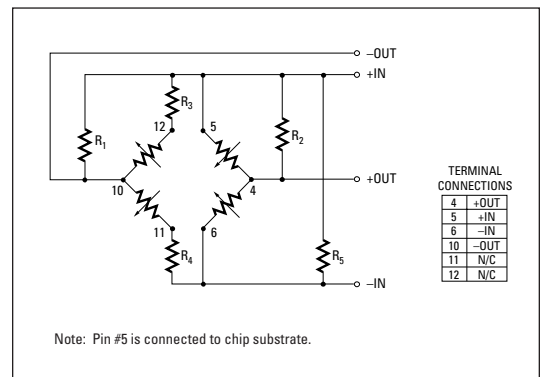

Applications

- Process Control, P-to-I Converters
- Pneumatic Control Systems
- HVAC Controls
- Biomedical: Infusion Pumps, Sphygmomanometers, Respirators
- Aerospace: Altimeters, Barometers, Cabin Pressure Sensors
- Computer Peripherals

Specifications

Parameter	Value	Units	Notes					
General								
Pressure Range	2.5	kPa	≈ 0–10" H ₂ O					
	7	kPa	≈ 0–1 psi					
	30	kPa	≈ 0–5 psi					
Maximum Pressure	5 x		rated pressure (10)					
Electrical @ 25°C (77°F) unless otherwise stated								
Input Excitation	1.5	mA	2mA max.					
Insulation Resistance	10 ⁷	Ω	@ 50 VDC					
Input Impedance	3,200	Ω	± 25%					
Output Impedance	5,000	Ω	± 20%					
Bridge Impedance	5,000	Ω	± 20%					
Environmental								
Temperature Range	Operating(9) Compensated	–40 to +125	°C					
		0 to +70	°C					
			–40 to +257°F +32° to +158°F					
Vibration	10	gRMS	20 to 2000Hz					
Shock	100	g	11 milliseconds					
Life (Dynamic Pressure Cycle)	1 x 10 ⁶	cycles						
Mechanical⁽¹⁾								
Weight	<5	grams	<0.2 oz.					
Media Compatibility	Noncorrosive gases and dry air							
Wetted Materials								
Top Port:	Nickel, gold plated Kovar, silicone gel, gold wire, RTV, silicon & glass.							
Bottom Port:	Gold plated Kovar, silicon, glass and RTV.(9)							
Parameter	Min.	Typ.	Max.	Min.	Typ.	Max.	Units	Notes
	2.5 kPa			7 & 30 kPa				
Performance Parameters⁽⁷⁾, Compensated⁽¹⁾								
Offset	–8	± 2	8	–4	± 2	4	mV	
Full Scale Output								
2.5 kPa	25	50	90				mV	2
7 kPa				50	75	150	mV	2
30 kPa				75	100	125	mV	2
Linearity	–1.0	0.1	1.0	–0.25	0.05	0.25	%FSO	3
Hysteresis and								
Repeatability	–0.2	0.05	0.2	–0.2	0.05	0.2	%FSO	
Thermal								
Accuracy of Offset	–3	0.5	3	–2	0.5	2	%FSO	4
Thermal								
Accuracy of FSO	–3	–1	3	–1.5	–0.5	1.5	%FSO	4
Thermal Hysteresis	–0.75	±0.5	0.75	–0.5	±0.2	0.5	%FSO	5
Short-Term Stability of Offset		5			5		μV/V	6, 11
Short-Term Stability of FSO		5			5		μV/V	6, 11

Notes: 1. Performance with offset, thermal accuracy of offset, and thermal accuracy of FSO compensation resistors. 2. FSO with 1.5mA input excitation. 3. Best fit straight line. 4. 0 to +70°C with reference to 25°C 5. 0 to +70°C, by design 6. Normalized offset/bridge voltage —100 hrs, typical value, not tested in production. 7. All values measured at 25°C and at 1.5mA, unless otherwise noted. 8. Reduced performance outside compensation range. 9. Backside differential tube is nickel or Kovar. 10. Top side pressure. 11. Typical specifications are for reference only; absolute values may vary.



Dimensions and Ordering Information

Package Diagram

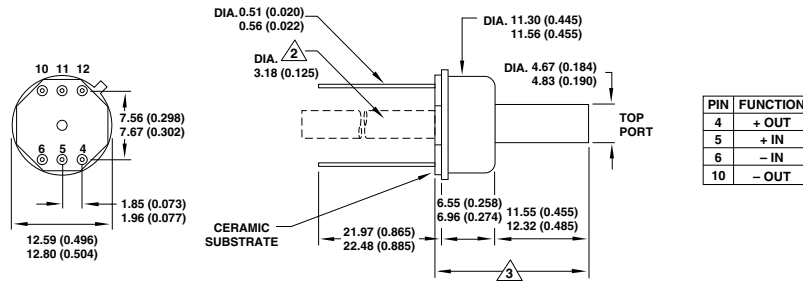

Notes: 1. All dimensions in millimeters (inches). 2. Backside differential tube is 17.15 ±0.051 (0.675 ±0.010) long, measured from back of header to tip, not from backplane of ceramic to tip. 3. Length is 19.33 -0.635/+0.889 (0.761 -0.025/+0.035) for gage type and 19.33 -0.635/+1.40 (0.761 -0.025/+0.055) for differential type.

Ordering Information

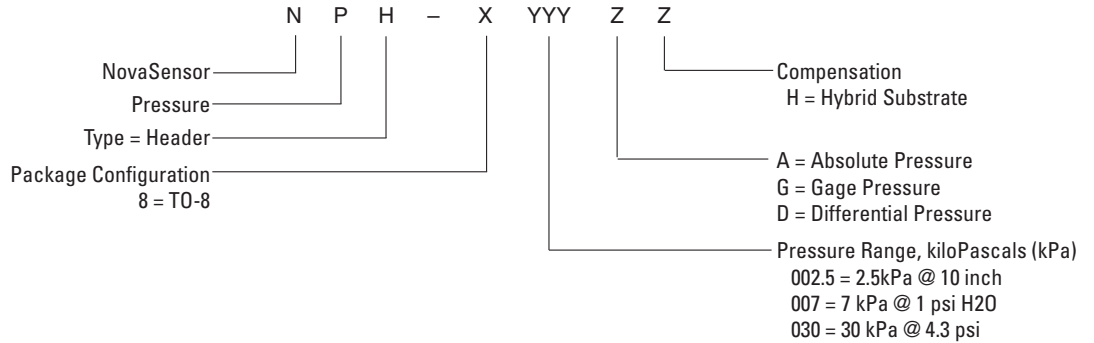

GE NovaSensor



Sales Terms:

NovaSensor standard sales terms apply.
Prices and specifications are subject to change without notice.

Warranty:

NovaSensor warrants its products against defects in material and workmanship for 12 months from the date of shipment. Products not subjected to misuse will be repaired or replaced. NovaSensor reserves the right to make changes without further notice to any products herein. NovaSensor makes no warranty, representation or guarantee regarding the suitability of its products for any particular application, nor does NovaSensor assume any liability arising out of the application or use of any product or circuit and specifically disclaims and all liability without limitation consequential or incidental damages. The foregoing warranties are exclusive and in lieu of all other warranties, whether written, oral, implied or statutory. NO IMPLIED STATUTORY WARRANTY OF MERCHANTABILITY OR FITNESS FOR PARTICULAR PURPOSE SHALL APPLY.

GE Novasensor
1055 Mission Court,
Fremont, California 94539
www.novasensor.com
Toll Free: 800-962-7364
Tel: 510-661-6000
Fax: 510-770-0645