

Flue Gas Oxygen Analyzers



GE Sensing & Inspection Technologies

Introduction

Industry leaders in the design and manufacture of advanced sensing and measurement solutions have combined their technological innovation and experience into one world-class business—GE Sensing & Inspection Technologies. This business, with operations around the world, offers a broad range of products and services that help customers solve challenges and drive productivity.

The Sensing & Inspection Technologies business of GE offers sensing elements, devices, instruments, and systems that enable customers to monitor, protect, control, and validate the safety of their critical processes and applications. The company supplies sensors, instruments and systems that measure temperature, pressure, level, humidity and flow rate for aerospace, automotive, oil and gas, pharmaceutical, power and other process and industrial industries. GE Sensing & Inspection Technologies draws upon many technologies and resources to provide our customers with the highest quality of calibration to ensure every technological process.

GE Sensing & Inspection Technologies is dedicated to developing technologies using ultrasonic and gas flow measurement, dew point measurement, thermal validation, control circuit protection, liquid level detection, process control instrumentation, and microstructure design for customizing solutions for our customers' particular applications.

Druck, General Eastern, Kaye, NovaSensor, Panametrics, Pressurements, Protimeter, Ruska, SI, Telaire and Thermometrics are now under one name: GE Sensing & Inspection Technologies.

Visit www.gesensing.com for more information.



GE Sensing & Inspection Technologies

Catalog

Panametrics OxyTrak 390 Flue Gas Oxygen Analyzer	3
Panametrics FGA 311 In Situ Flue Gas Oxygen Transmitter	6
Panametrics FGA 300 Flue Gas Oxygen Analyzer	9

Panametrics OxyTrak™ 390 Flue Gas Oxygen Analyzer

The OxyTrak 390 flue gas analyzer utilizes the ex situ connection loop design, and it is an accurate, low-cost analyzer that stays on the job for extended periods with minimal maintenance. Using the information the analyzer provides, you can adjust your burner air supply for maximum combustion efficiency. The optional combustibles detector can be used to monitor burner operation for further improvements in efficiency and safety.



Applications

The OxyTrak 390 flue gas analyzer measures unburned oxygen levels in dirty, aggressive combustion applications including

- Boilers: all fuels and all types, including marine, recovery, and utility
- Furnaces: all fuels and all types, including heat treating, glass and process
- Rotary kilns: ore reduction, cement, alumina processing and others
- Incinerators: industrial, municipal and hazardous waste

Features

- Ex situ diffusion/convection loop design with zirconium oxide oxygen sensor for measurement accuracy and durability
- Sensor housing maintains steady temperature for greater accuracy and longer sensor life
- Automatic calibration and verification
- Optional sensor to measure CO, H₂ and other combustibles
- Corrosion-resistant design
- Plug-resistant sample path
- Easy installation and sensor replacement
- Suitable for temperatures up to 3452°F (1900°C)

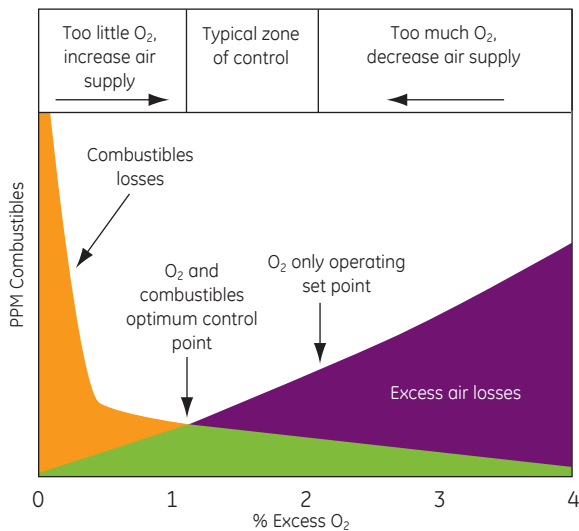

Typical Combustion Control Scenario

Why Monitor Flue Gas?

Ideally, every burner should mix a precise ratio of air and fuel, and the fuel should burn stoichiometrically to yield only heat, water vapor and carbon dioxide. In reality, this rarely happens. Burners age, mixing is imperfect, calorific value of fuel varies, firing rates change, and the weather changes from day to day. Any of these factors can change the amount of air required for safe and efficient combustion of fuel. Accurate flue gas analysis minimizes fuel costs and reduces pollution in all combustion processes.

OxyTrak 390 Series—A Step Ahead of Traditional Flue Gas Analyzers

The OxyTrak 390 combines state-of-the-art measurement technology with a unique sampling design. The result is an accurate, low-cost analyzer that stays on the job for extended periods with minimal maintenance. It responds in seconds to changes in flue gas concentrations of oxygen and/or combustibles, constantly providing the information you need to keep your boiler or furnace operating at maximum efficiency.

OxyTrak 390 Special Design Features

Stable, Accurate, Wide-Range Oxygen Sensor

The zirconium oxide oxygen sensor is housed in a furnace that maintains the O₂ sensor at a steady 1292°F (700°C). The temperature stability improves accuracy and extends the sensor's life.

Corrosion-Resistant Design

The manifold heater block located at the sample inlet prevents manifold corrosion due to flue gas acid condensation, ensuring maximum analyzer life with minimum maintenance.

Optional Platinum-Catalyst Combustibles Sensor

A unique platinum-catalyst sensor is available to measure levels of combustibles (CO plus H₂). This is useful for detecting incomplete combustion or defective burner equipment.

Simple Installation

The OxyTrak 390 can be installed on a flue or furnace on an existing flange mount. Because it utilizes the ex situ convection loop design, reference air is not needed.

Fast, Easy Routine Maintenance

Calibration is easily achieved by introducing a calibrated gas through the convenient calibration port and making an automatic adjustment via the display controller. For sensor replacement, there is no need to remove the entire analyzer from the flue. Since the sensor is ex situ, it can be quickly removed with basic tools.

Plug-Resistant Sample Path

A diffusion-based sampling technique greatly reduces the entry of particulates into the analyzer. If necessary, quick and easy cleaning is possible without disassembling the unit.

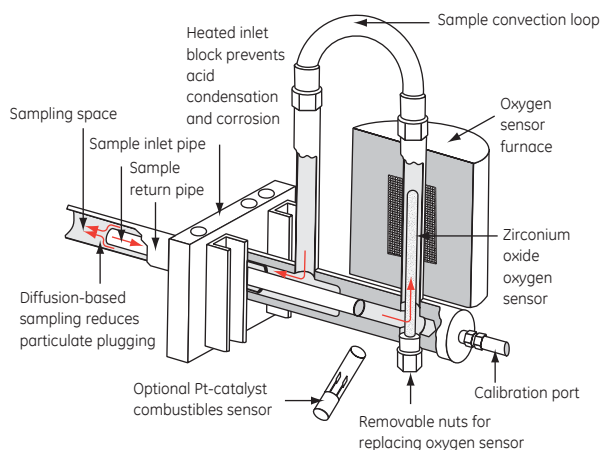

OxyTrak 390 Sampling Schematic Diagram

OxyTrak 390 Specifications

Performance

Accuracy

- Oxygen: $\pm 0.1\%$ O₂ (0 to 10% O₂) and $\pm 0.2\%$ O₂ (10 to 25% O₂)
- Combustibles (Optional): ± 100 ppm or $\pm 5\%$ of reading, whichever is greater

Repeatability

- Oxygen: $\pm 0.05\%$ O₂ (0 to 10% O₂) and $\pm 0.1\%$ O₂ (10 to 25% O₂)
- Combustibles (Optional): ± 50 ppm or $\pm 2\%$ of reading, whichever is greater

Output Resolution

- Oxygen: $\pm 0.01\%$ O₂
- Combustibles (Optional): $\pm 1\%$ of full scale (FS)

Stability

- Oxygen: $< 0.2\%$ O₂ per year
- Combustibles (Optional): < 200 ppm per year

Measurement Range

- Oxygen: 0 to 1% O₂ to 0 to 100% O₂, user-selectable
- Combustibles (Optional): 0 to 2000/5000/10,000 ppm; 0 to 2%

Response Time

- Oxygen: 90% step change within 20 seconds typical
- Combustibles (Optional): 90% step change within 20 seconds typical

Display

Intuitive, state-of-the-art microprocessor-based controller displays readings for up to three user-specified process conditions (% O₂, ppm combustible, furnace temperature, heater block temperature)

Output

- Analog: three linearized, isolated, 4 to 20 mA outputs, user selectable, field programmable for O₂ or combustibles over any range

GE Sensing & Inspection Technologies

- Alarm: eight configurable relays
 - Oxygen: high and low
 - Combustibles: high and low
 - Autocalibration or autoverification, two relays for O₂ and/or two relays for combustibles
 - System fault
 - Blowback feature
- Digital: Standard, PanaView™ via RS485 or RS232, user selectable

Ambient Temperature Range

- Analyzer: -22°F to 158°F (-30°C to 70°C)
- Display/controller: -4°F to 140°F (-20°C to 60°C)

Sensor Temperature

- Standard: 1292°F (700°C)
- Optional: 1418°F (770°C)
- Optional: 1493°F (812°C) for high sulfur applications

Flue Gas Temperature Range/Probe Material

- Up to 1200°F (650°C)/316 stainless steel
- 1200°F to 1750°F (650°C to 950°C)/MA253 stainless steel
- 1750°F to 2900°F (950°C to 1600°C)/mullite
- 2900°F to 3452°F (1600°C to 1900°C)/alumina

Warm-Up Time

50 minutes typical

Calibration Verification

- 3 modes: Manual, AutoCal and AutoVerify
- Calibration gas flow rate: 240 ± 10 cc/min

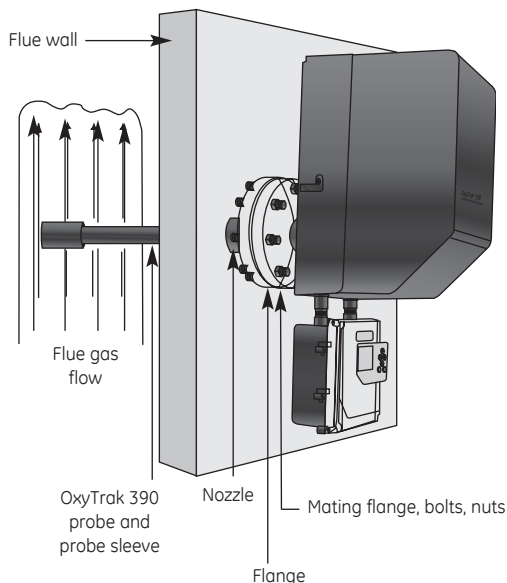

Typical Horizontal Flue Gas Analyzer Installation

Physical

Sensor Type

- Oxygen: Stabilized zirconium oxide
- Combustibles: Catalytic-combustion, platinum RTD (optional)

Wetted Materials

316 stainless steel

Probe Lengths

- Standard: 24 in (0.6 m), 39 in (1 m) or 55 in (1.4 m)
- Other lengths available upon request

Overall Dimensions (h x w x d)

22 in x 17 in x 12 in (559 mm x 431 mm x 305 mm), not including mounting flange or probe sleeve

Total Weight

25 lb (11.4 kg)

Mounting

- Standard: 1 1/2 in MNPT
- Optional: ANSI 150#, 3 in or 4 in CS flanges

Display/Controller

Enclosure and User Interface

- External six-button keyboard for field programming
- Large, 128 x 64 pixel LCD graphic display
- User-configurable display
- Local or remote installation of controller display (25, 50 and 100 ft standard cable lengths)
- Proprietary Proportional Integral Derivative (PID) control circuit (patent pending) provides the highest level of O₂ measurement accuracy via exceptional sensor furnace temperature control
- Weatherproof type: 4X, IP67 enclosure
- Size (h x w x d): 8.8 x 8.2 x 3.6 in (220 x 210 x 90 mm)

Output Load

600 Ω

Power

- Supply: 115, 230, 240 VAC ±10%, 50/60 Hz
- Consumption: 350W

European Compliance

Complies with EMC Directive 89/336/EEC, 73/23/EEC LVD (Installation Category II, Pollution Degree 2)

Panametrics FGA 311 In Situ Flue Gas Oxygen Transmitter

The FGA 311 is a simple, low-cost, in situ, flue gas oxygen transmitter. The zirconium oxide oxygen sensor is installed directly into the flue stack or furnace wall. For low-temperature applications, a heater is included to maintain a constant temperature on the zirconium oxide sensor. The FGA 311 is available in both weatherproof and explosion-proof configurations.

Typical applications for the FGA 311 include natural gas-fired utility and municipal boilers, as well as natural gas-fired process heaters. The FGA 311 is ideal for boiler and furnace manufacturers due to its low-cost, basic transmitter configuration.

Applications

An in situ oxygen transmitter for use in

- Natural gas or oil-fired utility boilers
- Natural gas or oil-fired process heaters

Features

- In situ flue gas transmitter
- Fast, easy installation and service
- Weatherproof and explosion-proof packages
- Field-programmable ranges
- RS232 communications
- Temperatures up to 1920°F (1050°C)
- Leave-in-place housing—replace sensor without uncoupling flange from process

Easy Installation

The FGA 311 can be supplied with standard NPT fittings or it can be mounted on existing process flanges, making installation quick, easy and inexpensive.

Easy Configuration

Output ranges for the FGA 311 are user-selectable via a switch or the RS232 interface to accommodate changing measurement needs.



Easy Troubleshooting

Users can quickly connect the FGA 311's RS232 interface to a PC and view detailed diagnostics via terminal emulation. The FGA 311's microprocessor can report sensor mV output, heater temperature and other system status information, allowing the user to determine quickly any necessary corrective action.

Easy Removal and Replacement of Sensor and Heater Assembly

Particulates and the corrosives of most flue gases are very harsh to instrumentation located within the process. Conventional in situ flue gas oxygen transmitters require removal of the whole analyzer from the sample point to replace the sensor and heater assembly. The unique design of the FGA 311 makes the replacement easy. The cover on the transmitter housing is unscrewed, the wire harnesses are disconnected, and the sensor and heater assembly are unscrewed and removed. The sensor and heater can then slide out. The transmitter housing and probe remain in place, reducing labor time and effort for any sensor and heater replacement needs.



Sensor and Heater Assembly

GE Sensing & Inspection Technologies

FGA 311 Specifications

Performance

Accuracy

±3% of reading or 0.1% O₂

Measurement Resolution

Output 4 to 20 mA: 0.01 mA

RS232 Terminal Interface

0.01% O₂

Response Time

Less than 5 seconds for 63% of step change

Measurement Range

Fully field selectable via RS232 interface or onboard switches

- 0% to 5% O₂
- 0% to 10% O₂
- 0% to 25% O₂

Temperature

Process

- Standard: 300°F to 1200°F (150°C to 650°C)
- High temperature: 300°F to 1920°F (150°C to 1050°C)

Electronics

-4°F to 160°F (-20°C to 70°C) ambient

Calibration

Methods

- Semiautomatic by push-button
- RS232 interface
- Digipot adjustment

Recommended Gas Mixtures

5.0% O₂, balance N₂ (dependent on application and range)

Calibration Gas Flow

2000 cc/min (4 SCFH)

Reference Air

20 to 50 cc/min, clean, dry instrument quality air (20.93% O₂), regulated to 3 psi (0.2 bar)

Functional

Output

- Analog output: 4 to 20 mA DC, 600Ω maximum, isolated
- Digital output: RS232 communications

Power Consumption

- 115 VAC, 75 W
- 230 VAC, 135 W

Process Connection

- Standard: 1 1/2 in NPTM
- Optional: 2 in (50 mm) and larger flanges

Electrical Connection

- Signal: 3/4 in NPTF
- Power: 3/4 in NPTF

Physical

Probe Materials

- Standard temperature: 316 stainless steel
- High-temperature: Inconel® alloy

Probe Length

- Standard: 19 in (482.6 mm)
- Optional: x in, x in (1 m, 1.5 m), explosion-proof exclusion

Weight

15 lb (6.8 kg)

Mounting

Vertical or horizontal

Weatherproof/Explosion-proof

- Weatherproof Type: IP66, NEMA 4X
- Explosion-proof Type: Class I, Div. 1, Groups C, D – ISSeP02ATEX028 X
Electronics: EEx d IIB T6
Process: EEx d IIB T2



Inside the FGA 311 Transmitter

GE Sensing & Inspection Technologies

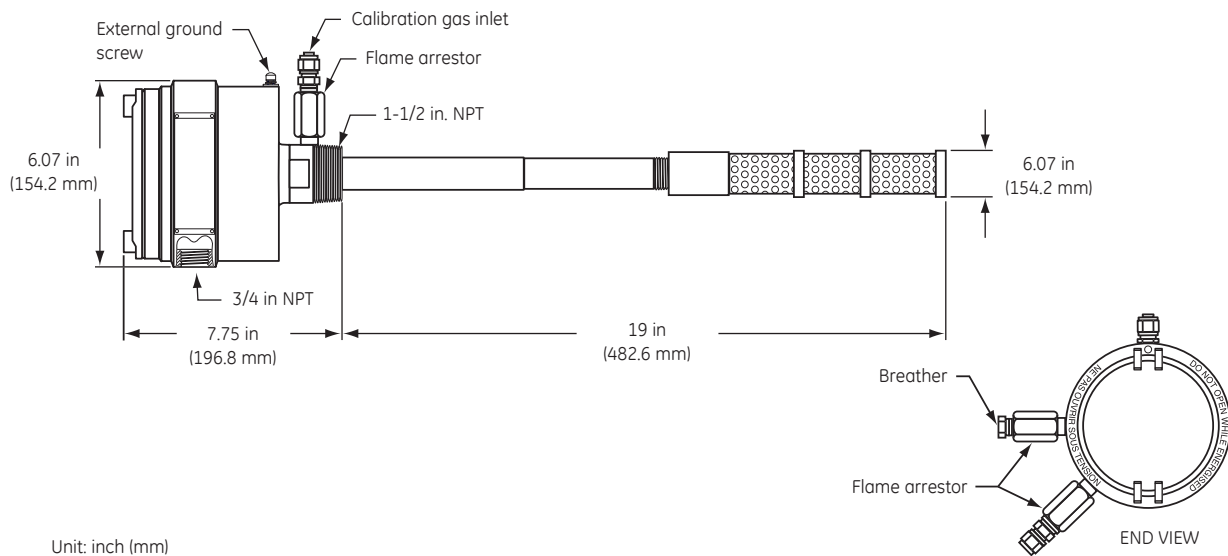

Explosion-proof Version of FGA 311 in Situ Oxygen Flue Gas Transmitter

Panametrics FGA 300 Flue Gas Oxygen Analyzer

The FGA 300 flue gas analyzer can pay for itself through fuel savings, reduced air pollution and improved product quality. Using the information the analyzer provides, you can adjust your burner air supply for maximum combustion efficiency. The optional combustibles detector can be used to monitor burner operation for further improvements in efficiency and safety.



Applications

The FGA 300 is an ex situ zirconium oxide analyzer for excess oxygen measurement in dirty, rugged combustion applications such as

- Boilers: all fuels and all types, including marine, recovery, and utility
- Furnaces: all fuels and all types, including heat treating, glass and process
- Rotary kilns: ore reduction, cement, alumina processing and others
- Incinerators: industrial, municipal and hazardous waste

Features

- Ex situ design for easy sensor replacement
- Sensor housing maintains steady temperature for greater accuracy and longer sensor life
- Optional sensor to measure H₂, CO and other combustibles
- Corrosion-resistant design
- Plug-resistant sample path
- Easy installation
- Horizontal or vertical installation in flue
- Explosion-proof/flameproof models
- Suitable for temperatures up to 3452°F (1900°C)

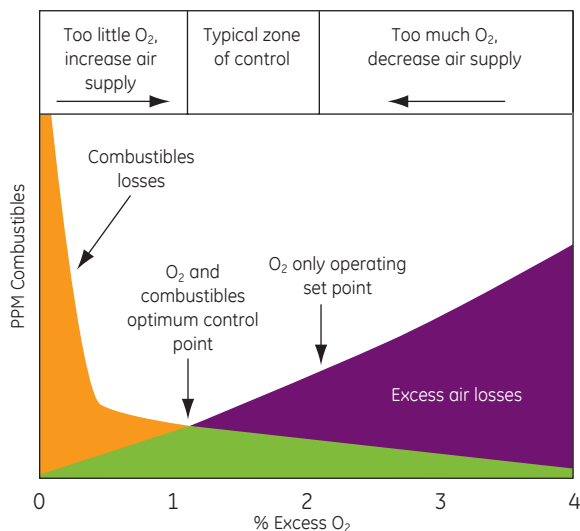

Typical Combustion Control Scenario

Why Monitor Flue Gas?

Ideally, every burner should mix a precise ratio of air and fuel, and the fuel should burn stoichiometrically to yield only heat, water vapor and carbon dioxide. In reality, this rarely happens. Burners age, mixing is imperfect, calorific value of fuel varies, firing rates change, and the weather changes from day to day. Any of these factors can change the amount of air required for safe and efficient combustion of fuel.

How much air is needed? Too little air sends unburned fuel to the stack—a costly and potentially explosive condition. Too much air wastes the heat of combustion by allowing excess hot air to go up the stack.

Accurate flue gas analysis minimizes fuel costs and reduces pollution in all combustion processes. Incomplete combustion can lead to increased air pollution. The amount of excess air influences SO₃ and NO_x formation. The correct air/fuel ratio minimizes the emission of pollutants.

Why the FGA 300 Is Better Than Traditional Flue Gas Analyzers

The designs of many flue gas analyzers have proven to be inadequate and unreliable under the harsh conditions in which they must operate. Particulate contamination often leads to premature sensor failure. The routine maintenance required can be difficult and time-consuming.

The FGA 300 overcomes these limitations by combining state-of-the-art measurement technology with a unique sampling design. The result is an accurate, low-cost analyzer that stays on the job for extended periods without requiring continual maintenance. It responds in seconds to changes in flue gas concentrations of oxygen and/or combustibles, constantly providing the information you need to keep your boiler or furnace operating at maximum efficiency.

GE Sensing & Inspection Technologies

Some analyzers measure flue gas temperature, which is used to perform efficiency calculations. The trouble with this is that to calculate efficiency accurately, the temperature measurement should be taken after the last heat exchanger. Oxygen content, however, is best measured as close as possible to the combustion zone and before the heat exchanger in order to minimize the effects of air leaks, which may bias the excess oxygen reading. This means that the efficiency calculated by these analyzers may be quite inaccurate. Because the FGA 300 is suitable up to 3452°F (1900°C), it can control excess O₂ in the stack location that is immediately adjacent to the furnace. Contact GE for our free combustion-efficiency slide chart.

Stable, Accurate, Wide-Range Oxygen Sensor

The oxygen sensor, a zirconium oxide cell, is housed in a special furnace that operates at a steady 1292°F (700°C). The temperature stability improves accuracy and extends the sensor's life.

Optional Platinum-Catalyst Combustibles Sensor

A unique platinum-catalyst sensor is available to measure levels of combustibles (CO plus H₂). This is useful for detecting incomplete combustion or defective burner equipment.

Corrosion-Resistant Design

The entire analyzer is kept heated to a temperature above the acid dew point of the flue gas. This prevents acid condensation and corrosion, ensuring maximum analyzer life with minimum maintenance.

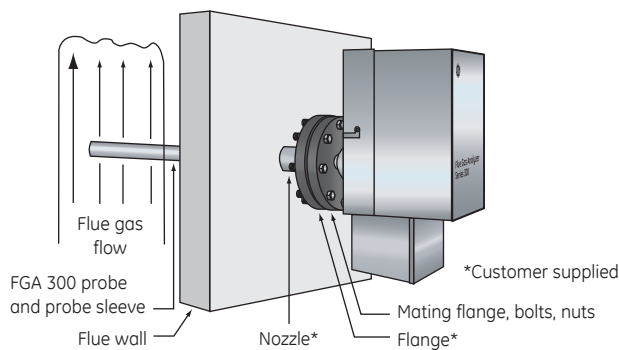

Typical Horizontal Flue Gas Analyzer Installation

Plug-Resistant Sample Path

A diffusion-based sampling technique eliminates or greatly reduces the entry of particulates into the analyzer. Should it ever become necessary, quick and easy cleaning is possible without disassembling the unit.

Fast, Easy Routine Maintenance

Calibration is easily achieved by using a calibration gas and making a single adjustment at the main analyzer. For sensor replacement, there is no need to remove the entire analyzer from the flue. Since the sensor is ex situ, it can be quickly removed with basic tools.

Simple Installation

The FGA 300 is easy to install. The FGA 300 can be installed on a flue or furnace using a standard or customer-supplied flange. Because it utilizes the ex situ connection loop design, reference air is not needed.

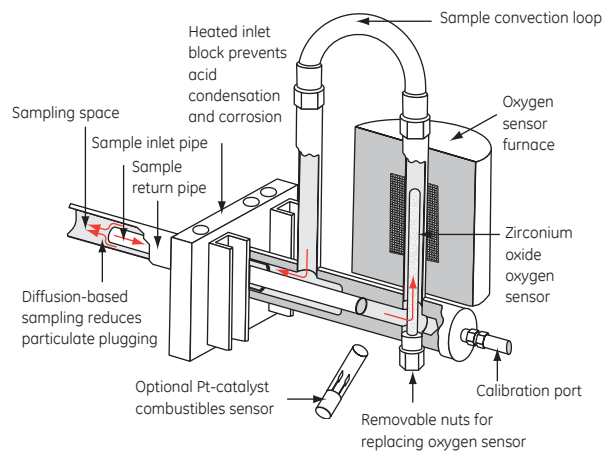

FGA 300 Sampling Schematic Diagram

GE Sensing & Inspection Technologies

Models for Every Application

The most basic version of the FGA 300 consists of a zirconium oxide oxygen sensor and diffusion convection sampling loop, combined with a logarithmic millivolt output inversely proportional to the oxygen concentration. The basic model can be customized with the following options to create a configuration optimized for the particular application.

- Linearized current output for oxygen concentration
- Microprocessor-based electronics console housed in an IP65 weatherproof enclosure
- Platinum-catalyst combustibles sensor housed in the main analyzer unit

Standard Horizontal and Vertical Mounting Configurations

The installation requirements of the application will generally determine whether the horizontal or vertical configuration is the best fit. In extreme cases of high dust loading, such as in cement kilns, an optional blow-back system can be added for manually or automatically blowing dust or dirt accumulation out of the sample probe.

Explosion-proof Configurations

The horizontal and vertical explosion-proof/flameproof configurations of the FGA 300 are ATEX-certified to EEx d IIC T4/T6. These units are typically used in furnace or process heater applications.

FGA 300 Specifications

Oxygen Analyzer

Sensor

Stabilized zirconium oxide

Accuracy

Linear output: $\pm 0.5\%$ of full scale (FS)

Repeatability

Linear output: $\pm 0.5\%$ of FS

Drift

Less than 0.1% of sensor output per month

Response Time

Standard: 90% of a step change within 20 seconds

Note: Faster speed of response available with optional air ejector/aspirator

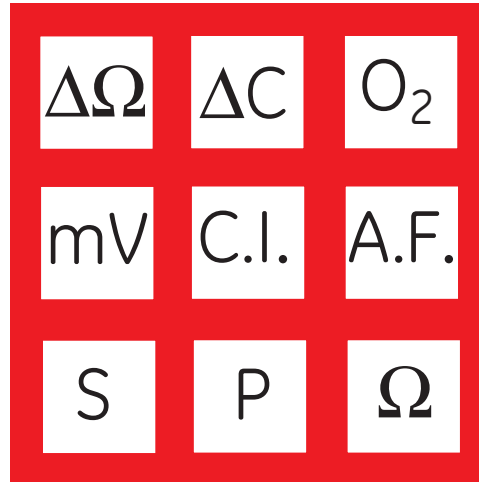

The default setting for the FGA 300's microprocessor-based electronics displays oxygen concentration, optional combustibles concentration, alarm output, and either current or voltage output. At the push of a button on the front panel, the default display can be overridden to show fuel and other parameters that may be more relevant to the individual process application. In addition, at the flip of a switch, you can select a particular fuel as the default fuel upon which all other calculations will be based. The buttons on the front panel display the following functions:



Equivalent Combustibles (H_2+CO)



Excess Fuel. This is useful for monitoring conditions when fuel is either deliberately or unintentionally in excess.

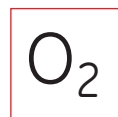

Percent Oxygen. This displays the amount of oxygen in excess of the stoichiometric quantity. This is the only accurate method for setting the proper air/fuel ratio.



Oxygen Sensor Millivolts. This displays the raw oxygen-sensor millivolt output, which indicates the oxygen sensor's operating condition.



Combustivity Index. The combustion air requirement index is needed when there are rapid, large changes in the fuel gas composition. (Optional hardware is required.)



Air Factor. Air Factor (ratio of air supplied to air needed for stoichiometric combustion) is often the preferred parameter to control furnaces that are operated from reducing through oxidizing conditions.



Oxygen Sensor Test. This button tests the operating condition of the oxygen sensor and warns in advance that replacement is necessary. This is used instead of automatic recalibration.

GE

Sensing & Inspection Technologies

Sample Probe Length

- 2 ft (0.6 m)
- 3 ft (1.0 m)
- 5 ft (1.4 m)
- Other lengths available on request

Sample Temperature

- Up to 1200°F (650°C)
- 1200°F to 1750°F (650°C to 950°C)
- 1750°F to 2900°F (950°C to 1600°C)
- 2900°F to 3450°F (1600°C to 1900°C)

Sample Dew Point

- Standard: 356°F (180°C) maximum
- Optional: Higher dew point version available

Ambient Analyzer Temperature

- Standard: -13°F to 158°F (-25°C to 70°C)
- Optional: Higher temperature version available

Power Requirements

- Supply: 100/110/220/240 VAC \pm 10%, 50/60 Hz
- Consumption: 480 W start-up maximum, 250 to 300 W in operation

Calibration

Through online calibration port using certified mixture of 5% O₂ in N₂

Warm-Up Time

Meets specified accuracy within one hour

Explosion-proof Classification

- FGA 300HX/VX Oxygen Analyzer: EEx d IIC T4 – ISSeP04ATEX078 X
- FGA 300FTC Furnace Temperature Controller-Electronic Unit: EEx d IIC T6 – ISSeP02ATEX071 X

Combustibles Analyzer

Sensor

Catalytic-combustion, platinum resistance thermometer

Accuracy

\pm 5% of FS

Repeatability

\pm 2% of FS

Drift

Less than 2% of FS per month

Response Time

Standard: 90% of a step change within 20 seconds

Calibration

Through online calibration port using certified mixture of CO and H₂ in N₂ with O₂

Warm-Up Time

Meets specified accuracy within one hour

Microprocessor-Based Electronics

AC Power Supply and Power Consumption

- AC Power Supply: 100/110/220/240 VAC \pm 10%, 50/60 Hz
- Power Consumption: 15 W

Operating Temperature

14°F to 122°F (-10°C to 50°C)

Storage Temperature

-67°F to 158°F (-55°C to 70°C)

Warm-Up Time

Meets specified accuracy in five minutes
Analyzer requires one hour

Output

0 to 20 mA/4 to 20 mA, isolated output, loop resistance 600 Ω or 0 to 10 VDC

GE

Sensing & Inspection Technologies

Displays

- Oxygen: four-digit LED
- Combustibles: 4.5-digit LED

Units

- Oxygen sensor, switch selectable: %, mV
- Combustibles sensor: 0 to 19,999 ppmV

Environmental

- Weatherproof: IP65
- Explosion-proof: EExd IIC T6 – ISSeP04ATEX076 X

Alarms

Two Form C relays for both oxygen and combustibles; rated 4 A at 110/220 VAC, 28 VDC

Alarms also activate for analyzer plugging and sensor failure.

Dimensions and Weights

Standard Horizontal Analyzer

- Dimensions (h x w x d): 22 in x 9 in x 14 in (555 mm x 235 mm x 350 mm)
- Weight: 37 lb (18 kg)

Standard Vertical Analyzer

- Dimensions (h x w x d): 23 in x 10 in x 11 in (590 mm x 265 mm x 280 mm)
- Weight: 33 lb (15 kg)

Explosion-proof Horizontal Analyzer

- Dimensions (h x w x d): 17 in x 28 in x 14 in (440 mm x 700 mm x 355 mm)
- Weight: 88 lb (40 kg)

Explosion-proof Vertical Analyzer

- Dimensions (h x w x d): 24 in x 27 in x 12 in (600 mm x 675 mm x 300 mm)
- Weight: 99 lb (45 kg)

Remote Furnace-Temperature Control Box

- Dimensions (h x w x d): 12 in x 9 in x 4 in (293 mm x 221 mm x 105 mm)
- Weight: 17 lb (8 kg)

Required for all configurations except standard horizontal

Rack-Mount Electronics

- Dimensions (h x w x d): 5.25 in x 19 in x 12 in (133 mm x 483 mm x 300 mm)
- Weight: 7 lb (3 kg)

Bench-Mount Electronics

- Dimensions (h x w x d): 4.5 in x 9.5 in x 12 in (120 mm x 240 mm x 300 mm)
- Weight: 7 lb (3 kg)

Panel-Mount Electronics

- Dimensions (h x w x d): 5.5 in x 10.5 in x 12 in (140 mm x 264 mm x 300 mm)
- Weight: 7 lb (3 kg)

Weatherproof Electronics

- Dimensions (h x w x d): 13 in x 11 in x 7 in (330 mm x 280 mm x 170 mm)
- Weight: 15 lb (7 kg)

Explosion-proof Electronics

- Dimensions (h x w x d): 18.3 in x 18.3 in x 10.4 in (465 mm x 465 mm x 255 mm)
- Weight: 103 lb (47 kg)

Other Options

- Remote logarithmic meter or linearized current output for basic model
- Automated or manual blow-back system for extreme conditions
- Aspirated sample extraction
- Customized systems for special applications including glass furnace and water washed system requirements. Please consult GE.

GE Sensing & Inspection Technologies



©2008 GE. All rights reserved.
BR-167A

All specifications are subject to change for product improvement without notice. GE® is a registered trademark of General Electric Co. Other company or product names mentioned in this document may be trademarks or registered trademarks of their respective companies, which are not affiliated with GE.

www.gesensing.com